

<b>HZ</b> ENGINEERING DIENSTLEISTUNGEN TEL: 015218124876 EMAIL: AYHAM.AWAD@ME.COM VENDOR		TITLE Preparation Line 2026 Beschreibung		Sachnummer PL-26		Version		Projektion- methode		Maßstab <b>1 : 20</b>		Maßeinheit mm		BLATT <b>1</b> VON <b>2</b>	
		Werkstoff				Mass 1292,735 kg				Halbzug		Genehmigt von A.Awad			
Dokumentenart		Projekt Preparation Line		Konstrukteur A.Awad		Genehmigt von		Zeichnung erstellt am		21.08.2010					

A3

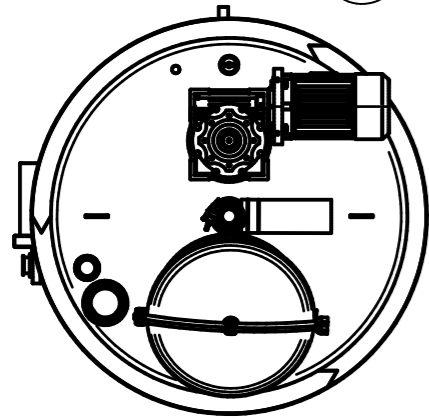
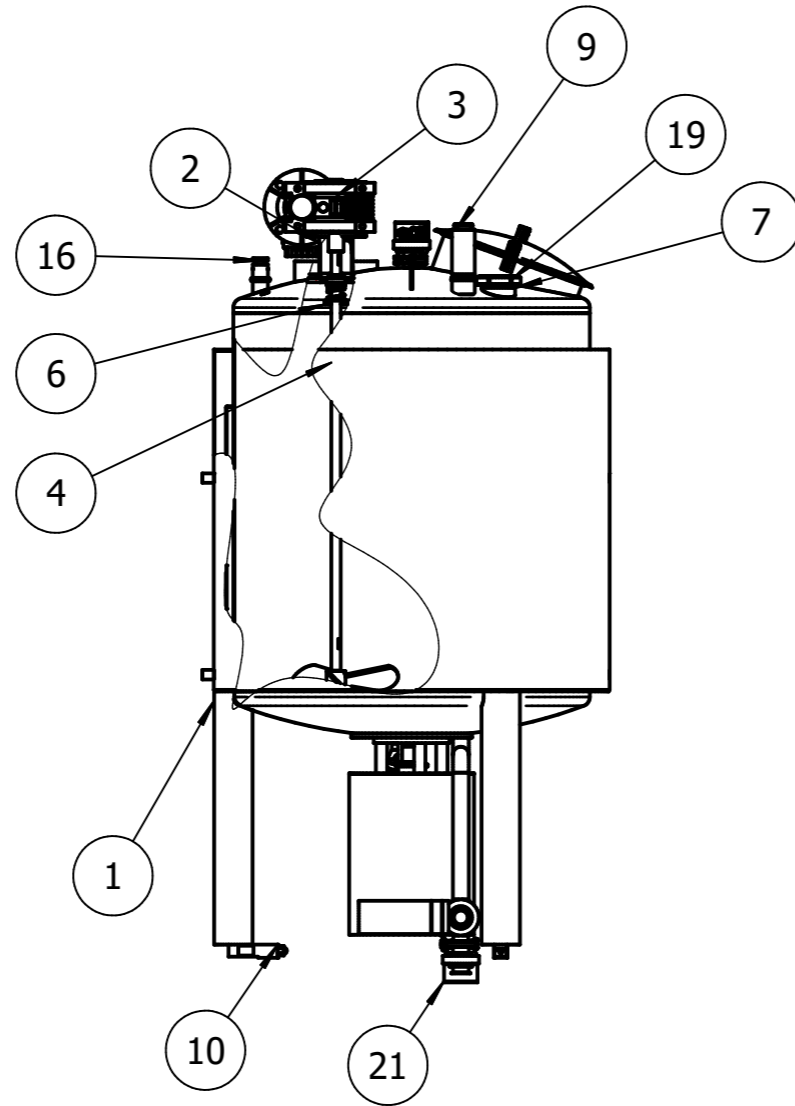
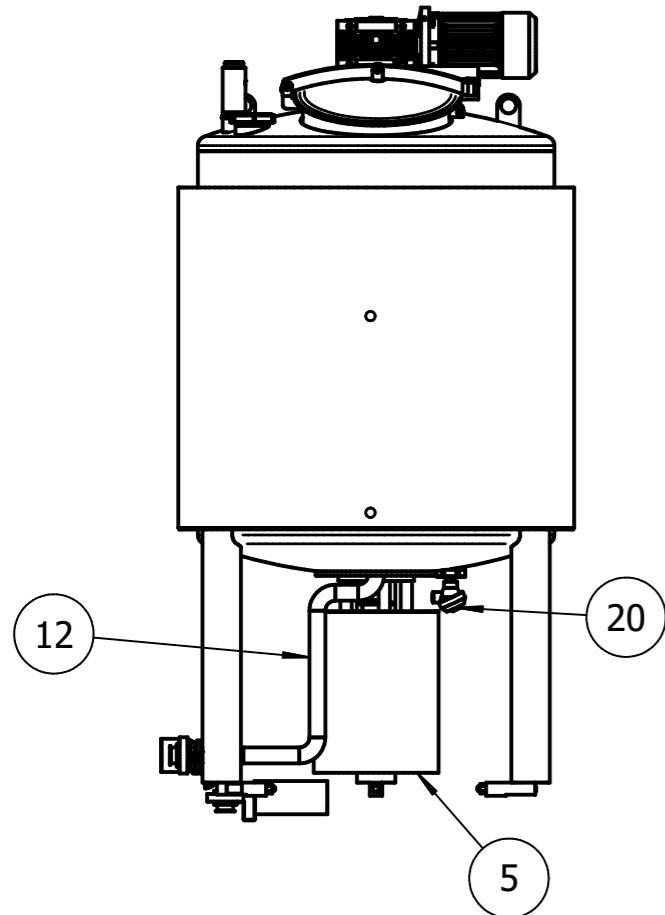
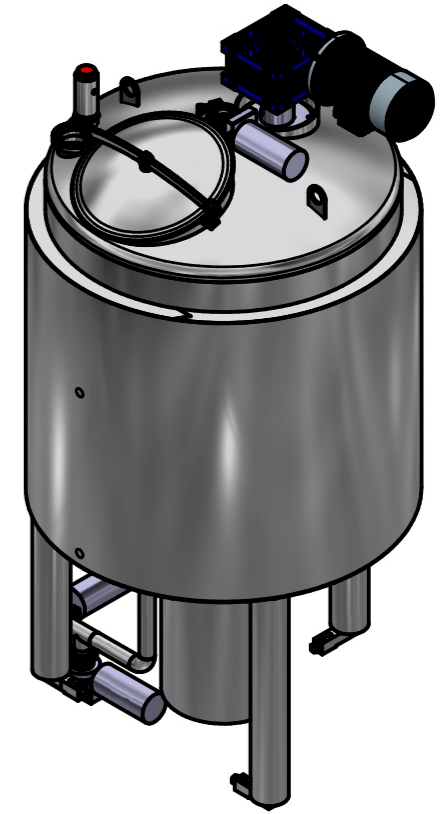
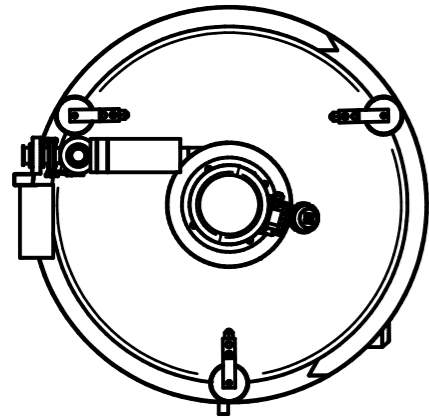

1	1	03-01	Preperation Line	
4	1	03-04	Preperation Line	Welded Stainless Steel, 440C
9	1	vision glass light	Preperation Line	
19	1	clamp vision glass	Preperation Line	
15	4	clamp 50 mm	Preperation Line	
17	1	shower bubble clamp1 in	Preperation Line	
3	1	03-03	Preperation Line	Stainless Steel 304
2	1	03-02	Preperation Line	Stainless Steel 304
14	1	mechanical seal-35 mm	Preperation Line	
6	1	03-06	Preperation Line	Stainless Steel 304
16	1	pressure vacum valve	Preperation Line	
24	1	MOTOVARIO-NMRV_090_200X24	Preperation Line	Stainless Steel 304
5	1	03-05H1_112_7.5hp_2800	Preperation Line	
22	3	ASME B16.9 Long Radius 90 Deg Elbow 1 1/4 x 0.109	Preperation Line	Stainless Steel 304
18	2	ferrol clamp 50	Preperation Line	Stainless Steel 316
8	1	o unions	Preperation Line	
20	1	emko heat sensour	Preperation Line	Stainless Steel
21	3	sudmo butter fly	Preperation Line	Stainless Steel
7	1	03-07	Preperation Line	Stainless Steel 304
23	1	ASME B16.9 Straight Tee 1 1/4 x 0.065	Preperation Line	Stainless Steel 304
11	1	pipe 1 1-4 - 11	Preperation Line	Stainless Steel 304
12	1	pipe 1 1-4 - 12	Preperation Line	Stainless Steel 304
13	1	pipe 1 1-4 - 13	Preperation Line	Stainless Steel 304
10	3	Load cell Sb210	Preperation Line	Stainless Steel 304
Pos.NR	Menge	Bennenung	Beschreibung	Material

BAUTEILLISTE

<b>HZ</b> ENGINEERING DIENSTLEISTUNGEN TEL: 015218124876 EMAIL: AYHAM.AWAD@ME.COM VENDOR		TITLE Preperation Line Beschreibung Werkstoff Mass 499,856 kg Halbzeug Dokumentenart		Sachnummer PL-03 Version Projekt Preperation Line Konstrukteur A.Awad Genehmigt von Zeichnung erstellt am 21.08.2010		Maßstab <b>1:20</b> Maßinheit mm Blatt <b>2</b> von <b>2</b>	
--	--	---	--	--	--	---	--

A3